

# Parts Catalogue

## Intermediate Disc Harrow Remote Control



**SANTA IZABEL**  
Implementos Agrícolas



# GICR

14 | 16 | 18 | 20 | 24 | 28

April / 2012



## GICR - TECHNICAL SPECIFICATIONS



Code	Model	Disc Diameter	Shaft Diameter	Disc Spacing	Cutting Width	Approximate Weight	Power Requirements (Wheel type)
10.33.1001	GICR 14	26"	1.5/8"	270 mm	1968 mm	1613 Kg	80 - 90
10.33.0001	GICR 14	28"	1.5/8"	270 mm	1968 mm	1652 Kg	80 - 90
10.33.1002	GICR 16	26"	1.5/8"	270 mm	2178 mm	1865 Kg	95 - 105
10.33.1003	GICR 16	28"	1.5/8"	270 mm	2178 mm	1910 Kg	95 - 105
10.33.2001	GICR 18	26"	1.5/8"	270 mm	2402 mm	1867 Kg	110 - 120
10.33.2002	GICR 18	28"	1.5/8"	270 mm	2402 mm	1918 Kg	110 - 120
10.33.1005	GICR 20	26"	1.5/8"	270 mm	2639 mm	1964 Kg	120 - 140
10.33.1004	GICR 20	28"	1.5/8"	270 mm	2639 mm	2020 Kg	120 - 140
10.33.1006	GICR 24	26"	1.5/8"	270 mm	3136 mm	2246 Kg	145 - 160
10.33.0003	GICR 24	28"	1.5/8"	270 mm	3136 mm	2313 Kg	145 - 160
10.33.1008	GICR 28	26"	1.5/8"	270 mm	3659 mm	2445 Kg	170 - 180
10.33.0004	GICR 28	28"	1.5/8"	270 mm	3659 mm	2523 Kg	170 - 180

"Pursuant to the continuous improvement program for the products of the company, the specifications contained herein may be changed without prior notice and without the commitment of altering pieces of equipment previously manufactured".





**GICR- 28**

Illustration

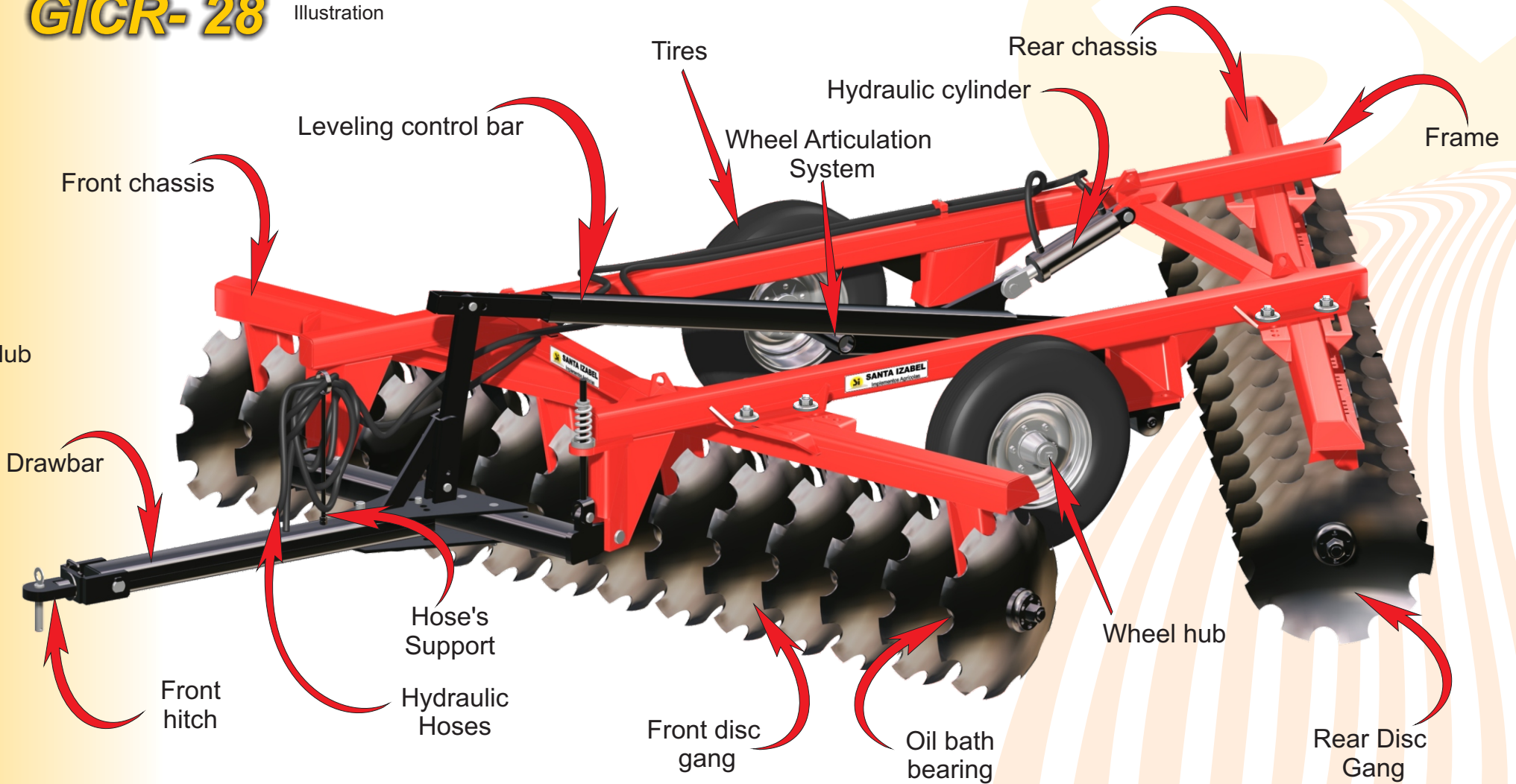

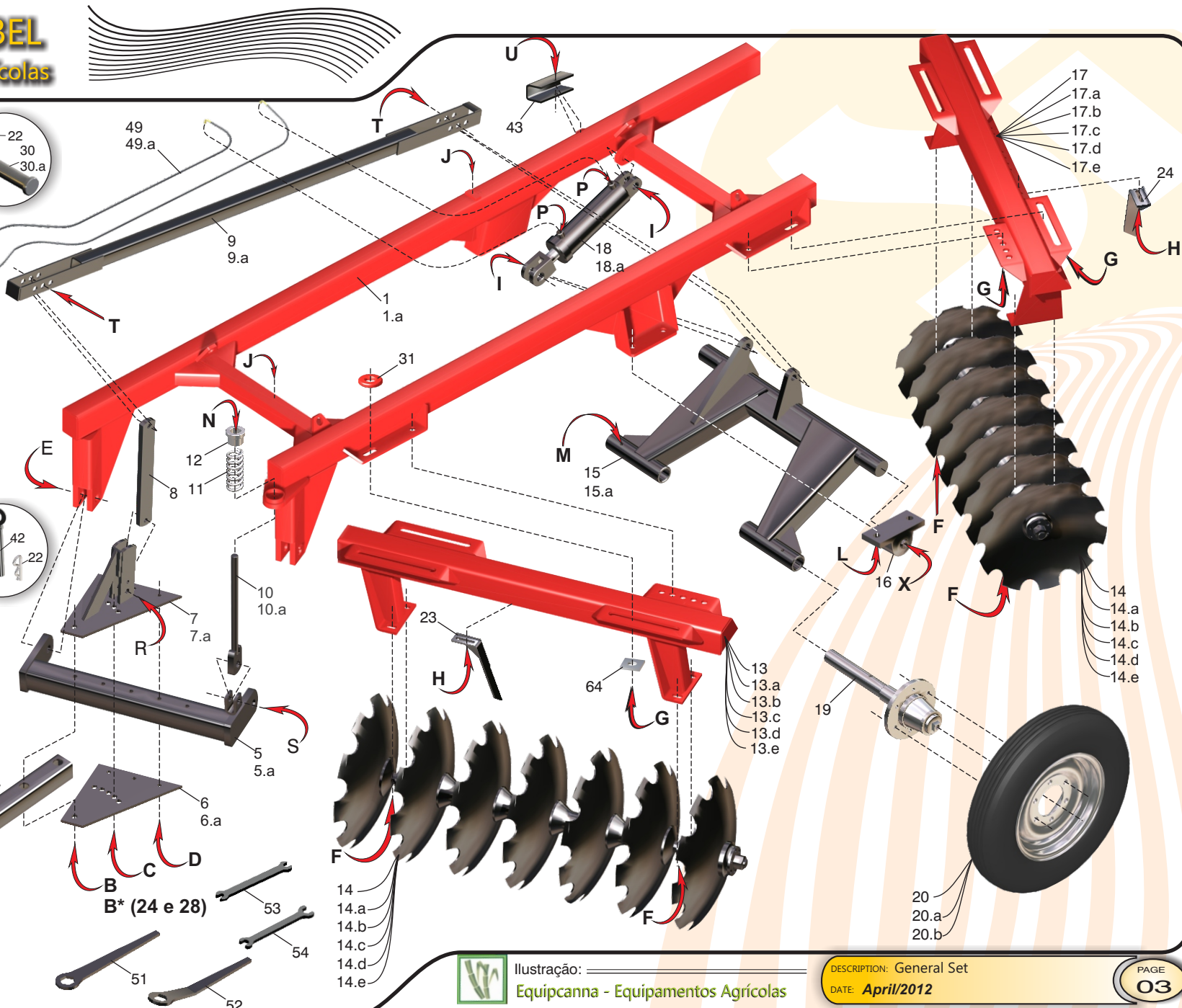
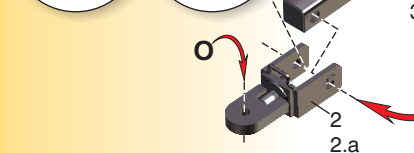
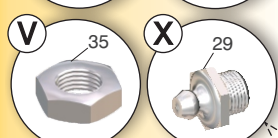
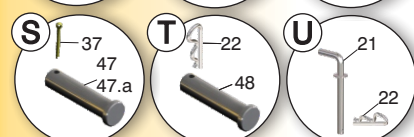
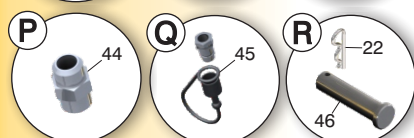
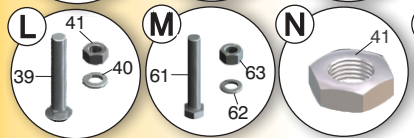
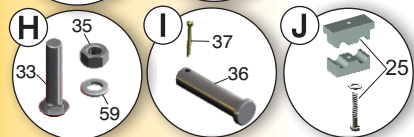
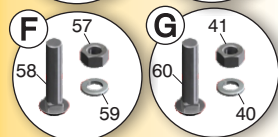
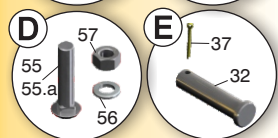



**GENERAL SET**

ITEM CODE	DESCRIPTION	14	16	18	20	24	28
01	20.33.0001 — Frame	01	01	01	01		
01.a	20.33.0028 — Frame					01	01
02	20.64.0009 — Hook	01	01	01	01		
02.a	20.49.0022 — Hook					01	01
03	20.33.0055 — Drawbar	01	01	01	01		
03.a	20.34.0019 — Drawbar					01	01
04	20.34.2029 — Hoses' Support	01	01	01	01	01	01
05	20.33.0054 — Offset Bar	01	01	01	01		
05.a	20.33.0043 — Offset Bar					01	01
06	21.33.0035 — Inferior Drawbar Plate	01	01	01	01		
06.a	20.33.0045 — Inferior Drawbar Plate					01	01
07	20.33.0007 — Superior Drawbar Plate	01	01	01	01		
07.a	20.33.0044 — Superior Drawbar Plate					01	01
08	20.33.0012 — Fixation Plate	01	01	01	01	01	01
09	20.33.0056 — Leveling Control Bar	01	01	01	01		
09.a	20.33.0047 — Leveling Control Bar					01	01
10	20.33.0008 — Spring Support	01	01	01	01		
10.a	20.33.0046 — Spring Support					01	01
11	40.13.5143 — Spring	01	01	01	01	01	01
12	20.34.2016 — Spring Internal Guide	01	01	01	01	01	01
13	20.33.0002 — Front Chassis	01					
13.a	20.33.0050 — Front Chassis		01				
13.b	20.33.0060 — Front Chassis			01			
13.c	20.33.0064 — Front Chassis				01		
13.d	20.33.0076 — Front Chassis					01	
13.e	20.33.0080 — Front Chassis						01
14	40.11.0032 — Gang Discs - GICR 14 (Page 09)	01				04	
14.a	40.11.0039 — Gang Discs - GICR 16 (Page 10)		01				04
14.b	40.11.0035 — Gang Discs - GICR 18 (Page 11)			01			
14.c	40.11.0027 — Gang Discs - GICR 20 (Page 12)				01		
14.d	40.11.0106 — Gang Discs - GICR 24 (Page 13)					01	
14.e	40.11.0107 — Gang Discs - GICR 28 (Page 14)						01
15	20.33.0004 — Whell Articulation Support	01	01	01	01	01	01
15.a	20.33.0040 — Whell Articulation Support	01	01	01	01	01	01
16	20.34.2022 — Wheel Articulation Bearing	02	02	02	02	02	02

ITEM CODE	DESCRIPTION	14	16	18	20	24	28
17	20.33.0003 — Rear Chassis	01					
17.a	20.33.0052 — Rear Chassis		01				
17.b	20.33.0062 — Rear Chassis			01			
17.c	20.33.0066 — Rear Chassis				01		
17.d	20.33.0078 — Rear Chassis					01	
17.e	20.33.0082 — Rear Chassis						01
18	40.03.0361 — Hydraulic Cylinder	01	01	01	01		
18.a	40.03.0362 — Hydraulic Cylinder					01	01
19	20.33.0042 — Wheel Hub (Page 16)	02	02	02	02	02	02
20	20.53.0093 — Assembled Wheel 6.00 x 16 (Page 15)	02					
20.a	20.53.0097 — Assembled Wheel 7.50 x 16 (Page 15)		02	02	02	02	02
20.b	20.18.0113 — Assembled Wheel 11L-15 Opt (Page15)	02	02	02	02	02	02
21	20.33.0026 — Lock Pin	02	02	02	02	02	02
22	40.13.0002 — Cotterpin	05	05	05	05	03	03
23	20.33.0048 — Front Scrape	04	04	05	06	07	09
24	20.33.0049 — Rear Scrape	04	04	05	06	07	09
25	40.16.0302 — Hose clamp - 22mm tube	02	02	02	02	02	02
26	20.64.0109 — Stud Bolt	01	01	01	01		
26.a	20.32.0032 — Stud Bolt					01	01
27	40.16.5094 — Castle Nut 1.1/4"UNC	01	01	01	01		
27.a	40.16.0172 — Castle Nut 1.1/2"UNC					01	01
28	40.03.5028 — Cotter Pin 1/4" x 3"	01	01	01	01	01	01
29	40.07.5034 — Grease Nipple	02	02	02	02	02	02
30	22.33.0086 — Drawbar Plate Pin	01	01	01	01		
30.a	22.33.0074 — Drawbar Plate Pin					01	01
31	20.34.0010 — Washer	08	08	08	08	08	08
32	20.33.0073 — Drawbar Fixation Pin	02	02	02	02	02	02
33	40.16.0010 — Bolt 5/8" x 2" UNC	16	16	20	24	28	36
34	40.01.5270 — Spring Washer 5/8" ZB	16	16	20	24	28	36
35	40.16.5080 — Hex. nut 5/8" UNC	16	16	20	24	28	36
36	20.33.0019 — Cylinder Fixation Pin	02	02	02	02	02	02
37	40.03.0009 — Cotter Pin 1/4" x 2" ZB	06	06	06	06	07	07
38	40.16.0218 — Hex. Bolt 1" X 7" 8.8	01	01	01	01		
39	40.16.0006 — Hex. Bolt 1" x 3" RP UNC ZB	04	04	04	04	04	04





ITEM CODE	DESCRIPTION	14	16	18	20	24	28
40	40.01.5245 — Spring Washer 1"	13	13	13	13	13	13
41	40.16.5245 — Hex. Nut 1"UNC	14	14	14	14	14	14
42	20.64.0106 — Hook Pin	01	01	01	01	01	01
43	20.33.0025 — Articulation Cylinder Lock	01	01	01	01	01	01
44	40.14.5603 — Nipple MF 1/2" NPT MF 7/8" UNF JIC ZB-	02	02	02	02	02	02
45	40.13.0049 — Male coupler 1/2"	02	02	02	02	02	02
46	20.33.0017 — Stabilizer Plate Pin	01	01	01	01	01	01
47	20.33.0015 — Spring Support Pin	01	01	01	01		
47.a	20.21.0057 — Spring Support Pin					01	01
48	22.33.0084 — Stabilizer Bar Pin	02	02	02	02		
49	40.13.0235 — Hydraulic Hose 1/2" x 5500	01	01	01	01		
49.a	40.13.0236 — Hydraulic Hose 1/2" x 6000	01	01	01	01	01	01
50	40.12.0237 — Hydraulic Hose 1/2" x 6500					01	01
51	20.66.0123 — Straight Spanner	01	01	01	01	01	01
52	20.66.0127 — Angled Spanner	01	01	01	01	01	01
53	22.34.2049 — Spanner 1/2" and 5/8"	01	01	01	01	01	01
54	22.34.2050 — Spanner 3/4" and 1"	01	01	01	01	01	01
55	40.16.5252 — Hex. Bolt 3/4" UNC x 6.1/2"	03	03	03	03		
55.a	40.16.5253 — Parafuso Sext. 3/4" x 6" UNC					03	03
56	40.01.5242 — Spring Washer 3/4"	03	03	03	03	03	03
57	40.16.5079 — Hex. Nut 3/4" UNC	11	15	15	15	19	19
58	40.06.0043 — Square Head Bolt 3/4" UNC x 3.1/2"	08	12	12	12	16	16
59	20.34.0077 — Washer 3/4"	08	12	12	12	16	16
60	40.16.5580 — Hex. Bolt 1" UNC x 3.1/2"	08	08	08	08	08	08
61	40.16.2055 — Hex. Bolt 1/2" BSW x 4"	02	02	02	02	02	02
62	40.01.5315 — Spring Washer 1/2"	02	02	02	02	02	02
63	40.16.5105 — Hex. Nut 1/2"	02	02	02	02	02	02
64	20.33.0023 — Chassis Plate	08	08	08	08	08	08
65	20.32.0070 — Stud Bolt					01	01
66	40.16.5025 — Castle Nut 1.3/8" UNF					01	01
67	40.03.5027 — Cotter Pin 3/16" x 2"					01	01





## OIL BATH BEARING

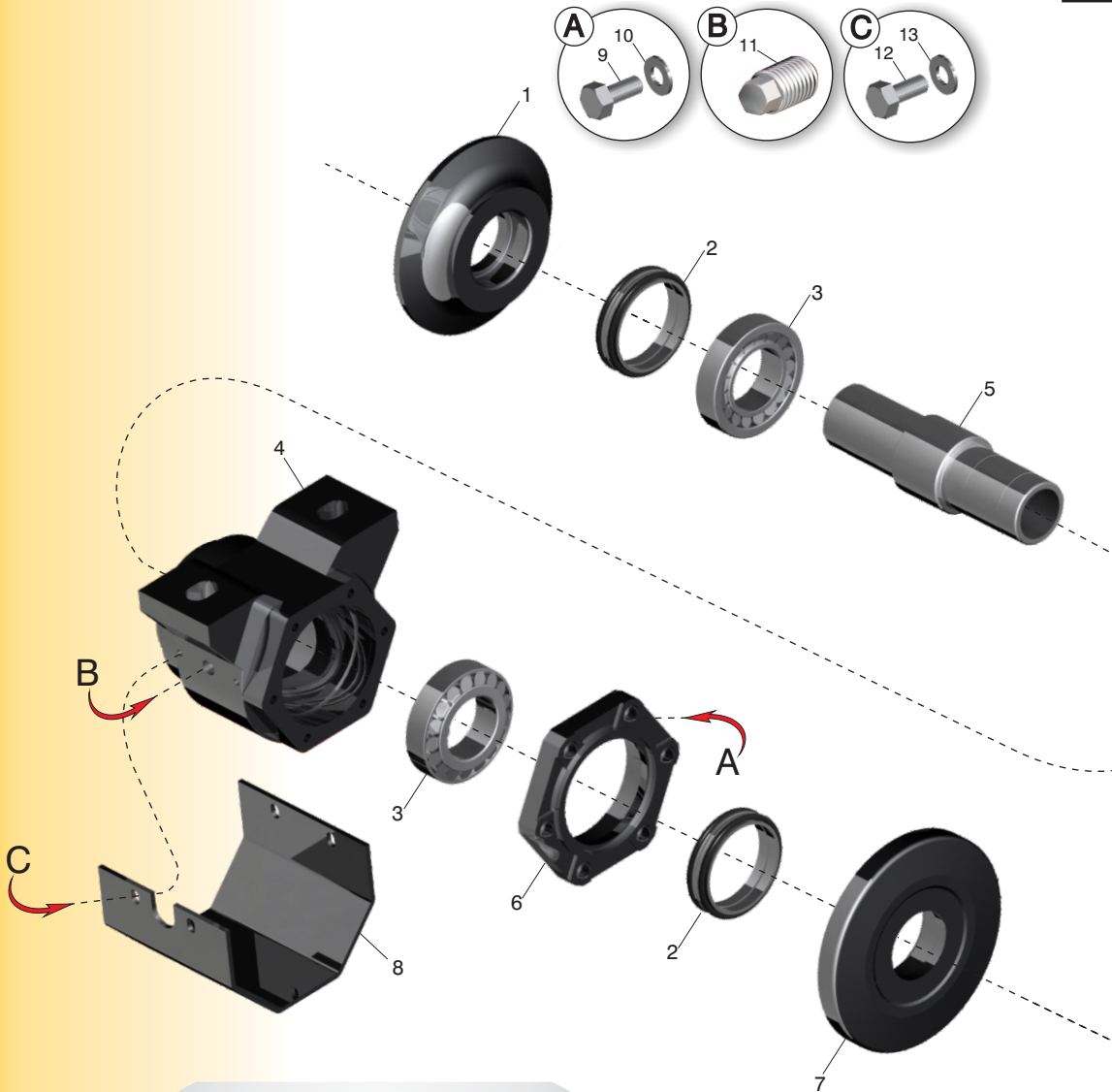

ITEM	CODE	DESCRIPTION	QUANTITY
01	40.01.0299	Convex Washer	01
02	40.18.0132	Duo Cone Retainer	02
03	40.18.0131	Bearing	02
04	40.03.0573	Housing Bearing	01
05	40.05.0252	Bearing Axle	01
06	40.20.0422	Bearing Cap	01
07	40.01.0300	Concave Washer	01
08	40.03.0575	Bearing cover	01
09	40.16.5139	Hexagon Bolt 3/8" UNC x 1.1/4"	06
10	40.01.0053	Spring Washer 3/8"	06
11	40.02.0038	Drain Plug	01
12	40.16.5418	Hex. Bolt 1/2" x 3/4" UNC	02
13	40.01.5411	Flat Washer 1/2"	02

Fill it with IPICIL 1500 Oil  
(without soup) - Quantity: 0,400 Liters

(\* Silicon Ultra Cooper





**GICR - 14**

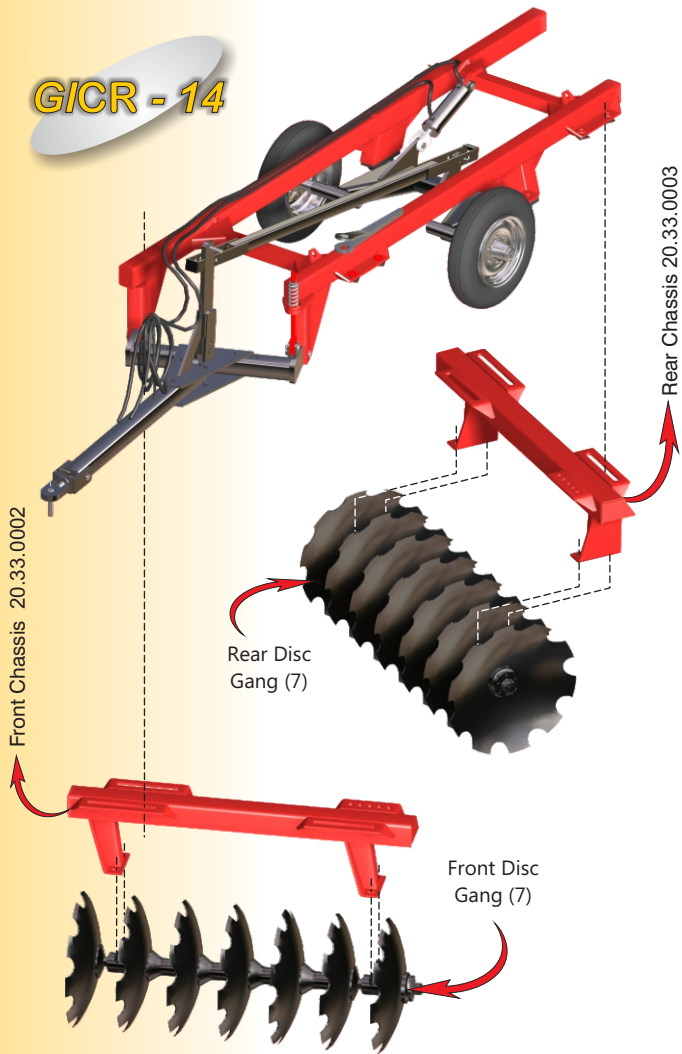

**GICR - 16**

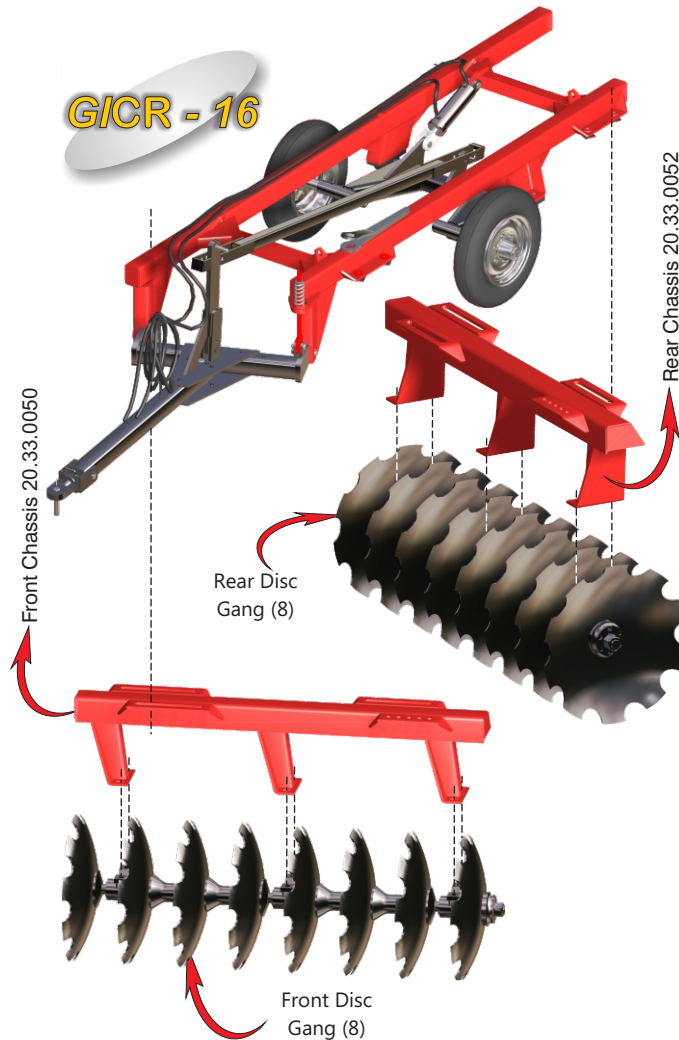

**GICR - 18**

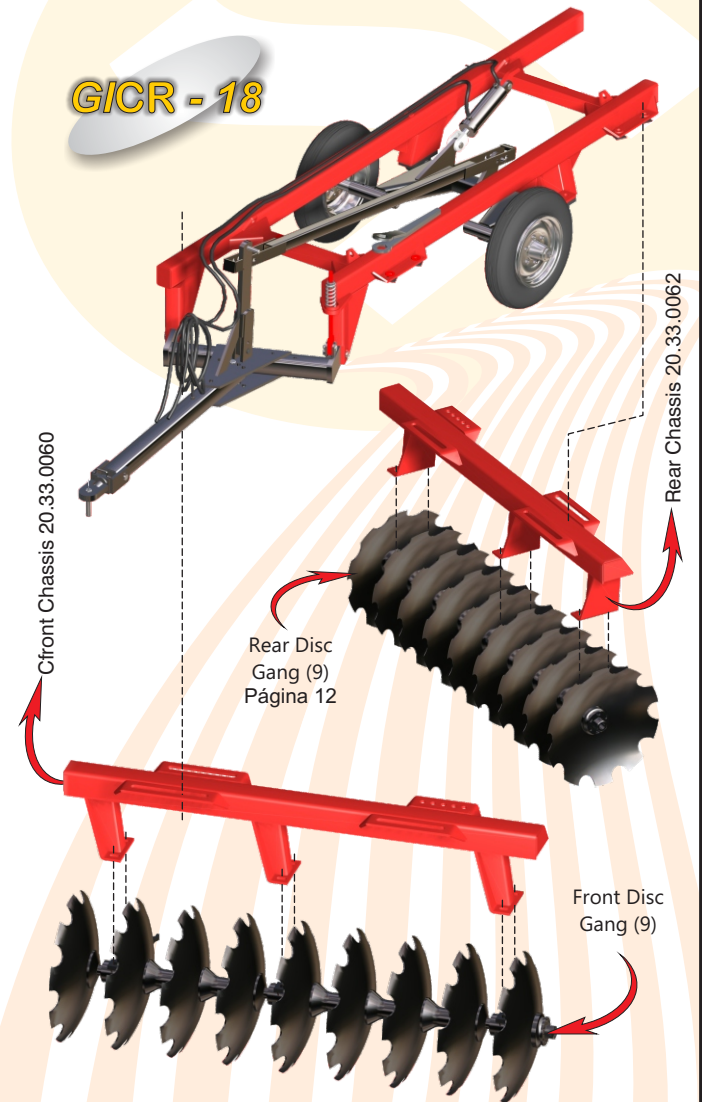

**Note:**

- This model can be assembled with 26" or 28" discs;
- There are some regulations on the chassis to adjust the disc gang;
- Front x Rear, offers more aggressive angle.







**GICR - 20**

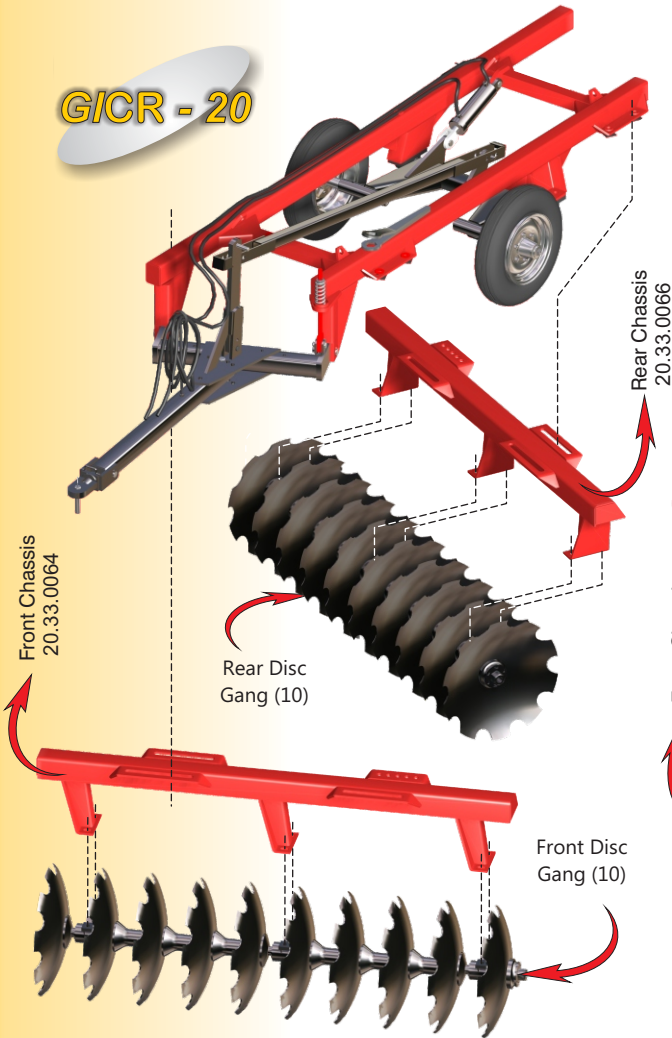

**GICR - 24**

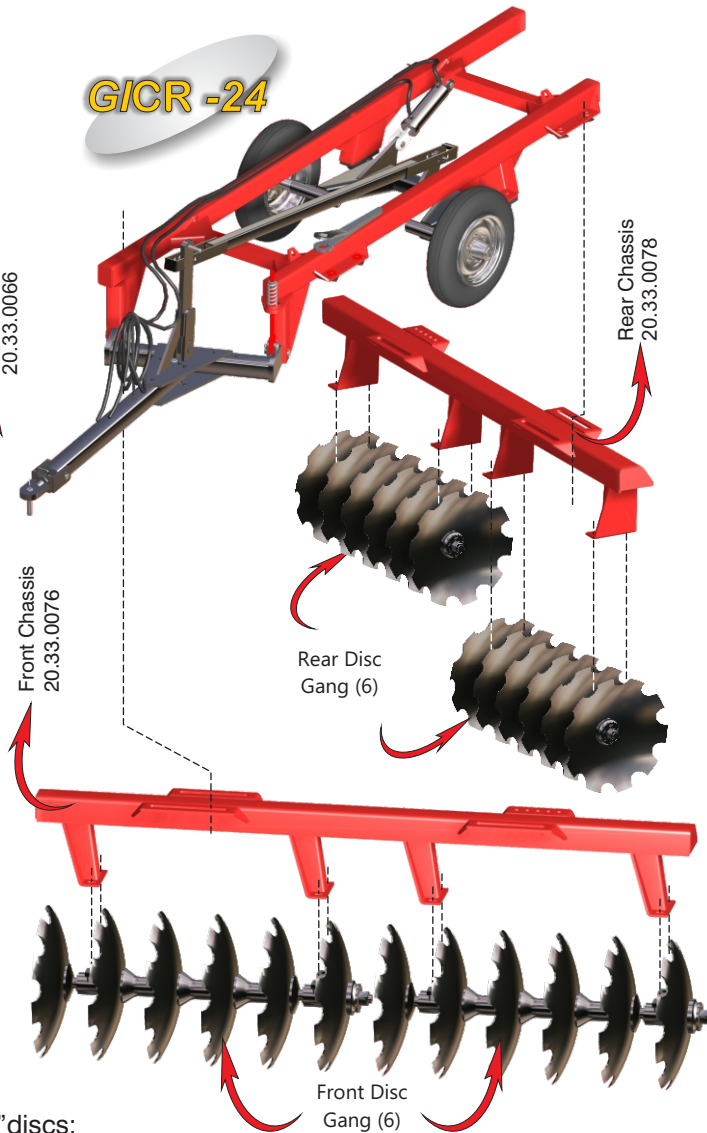

**GICR - 28**

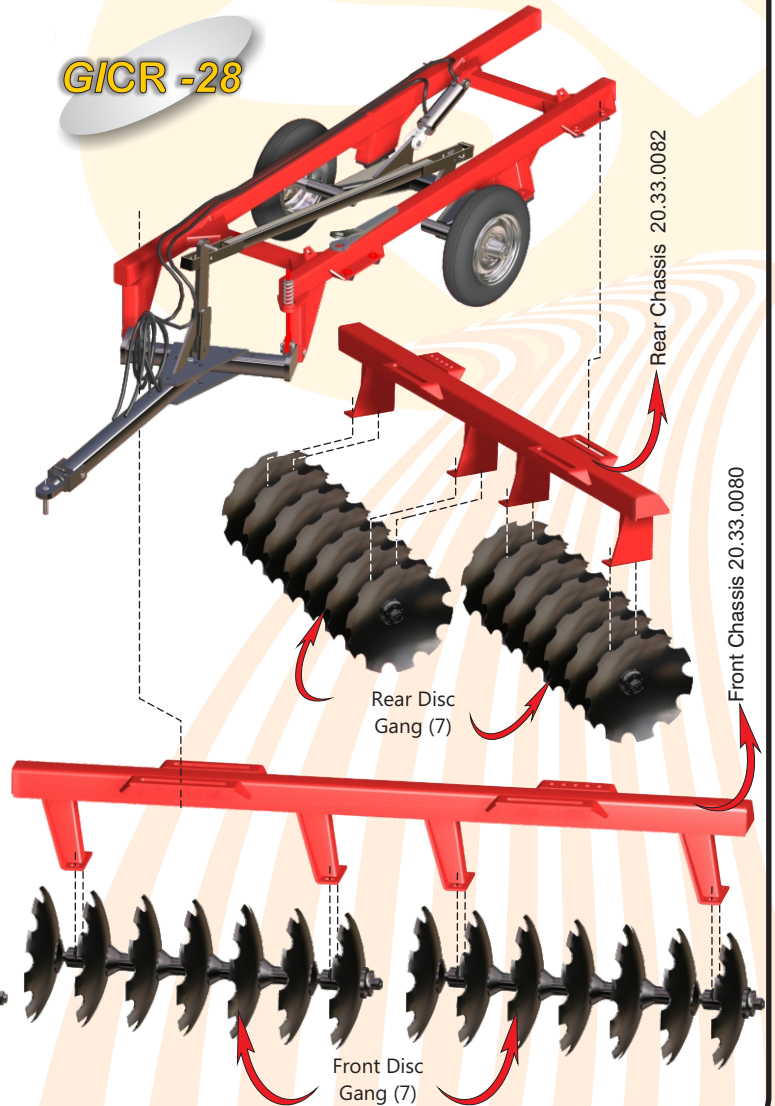

**Note:**

- This model can be assembled with 26" or 28" discs;
- There are some regulations on the chassis to adjust the disc gang;
- Front x Rear, offers more aggressive angle.





# GICR 14 DISC GANG

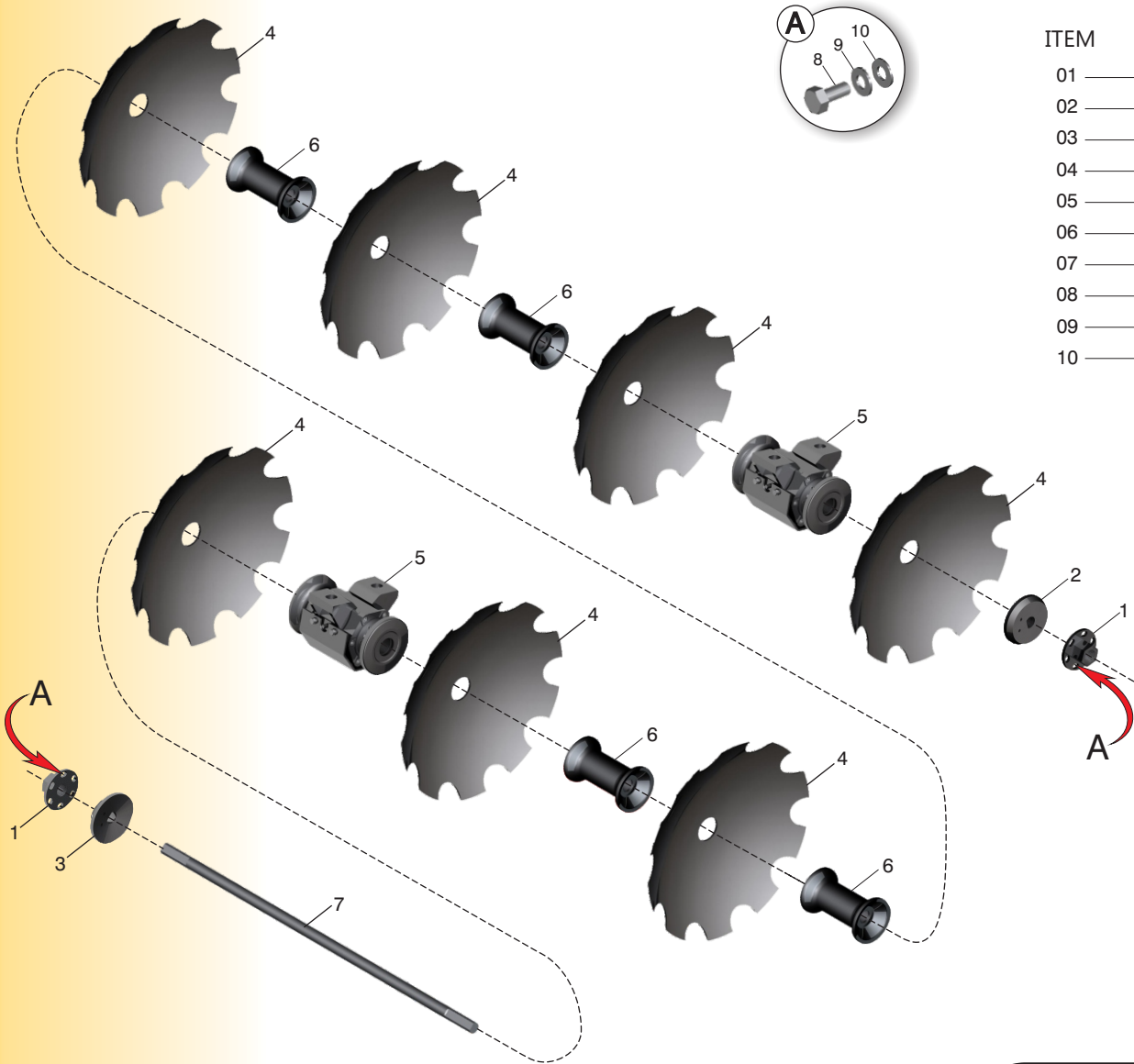

ITEM	CODE	DESCRIPTION	QUANTITY
01	40.16.0324	Flare Nut	04
02	40.01.0324	External Support	02
03	40.01.0323	Internal Support	02
04	40.04.5513	Notched Disc 26"	14
05	40.13.0137	Oil Bath Bearing 263mm (page 06)	04
06	40.19.0044	Spacer 263mm	08
07	40.05.0192	Shaft 1.5/8" x 1825mm	02
08	40.16.0155	Hex. Bolt 1/2" x 1.1/4" UNC	08
09	40.01.5411	Spring washer 1.2"	08
10	40.01.5315	Flat washer 1/2"	08

Note: -Standard Notched Disc: 26"  
-Option Notched Disc: 28" - 40.04.5514





# GICR 16 DISC GANG

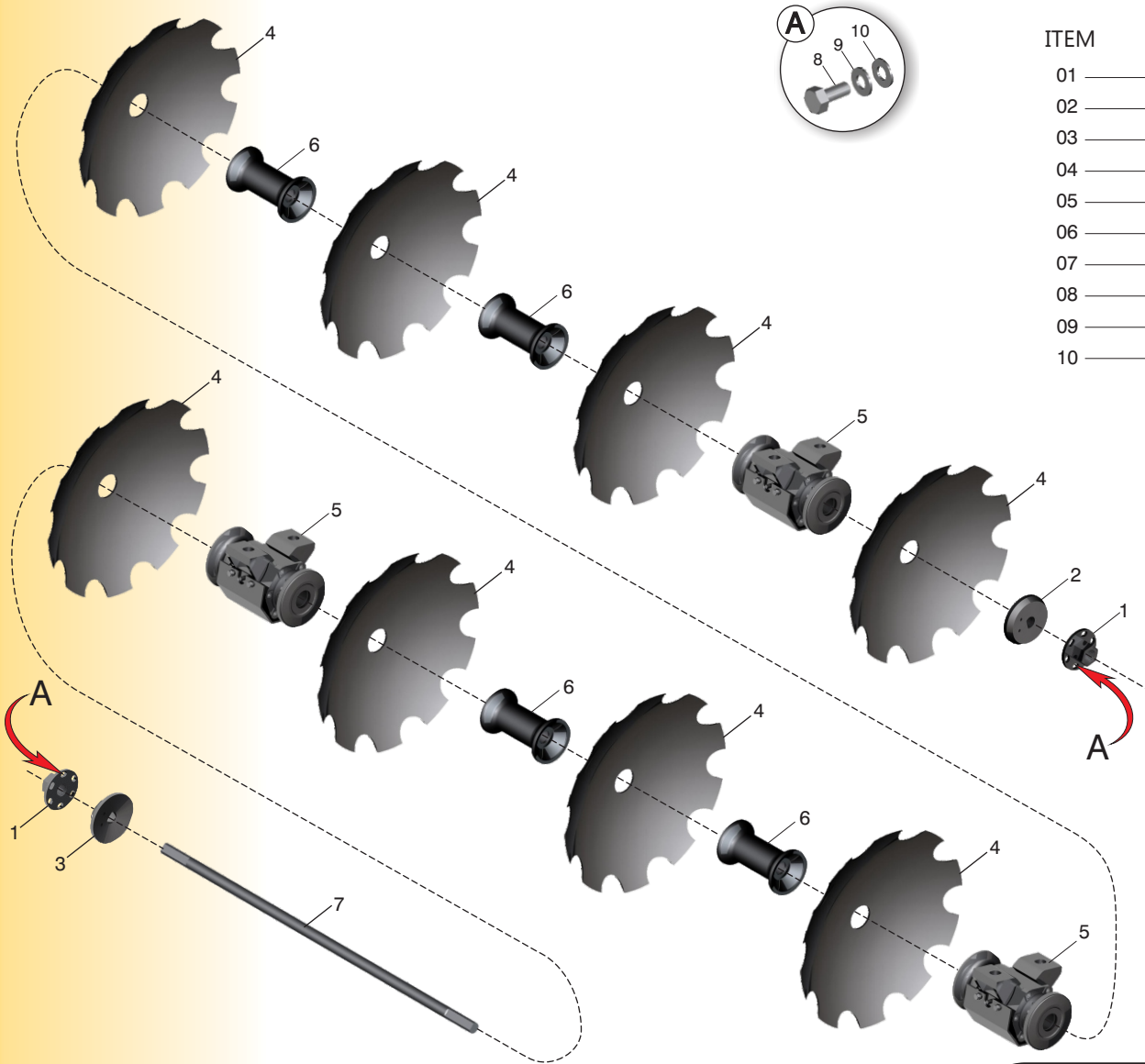

ITEM	CODE	DESCRIPTION	QUANTITY
01	40.16.0324	Flare Nut	04
02	40.01.0324	External Support	02
03	40.01.0323	Internal Support	02
04	40.04.5513	Notched Disc 26"	16
05	40.13.0137	Oil Bath Bearing 263mm (page 06)	06
06	40.19.0044	Spacer 263mm	08
07	40.05.0211	Shaft 1.5/8" x 2100mm	02
08	40.16.0155	Hex. Bolt 1/2" x 1.1/4" UNC	08
09	40.01.5411	Spring washer 1.2"	08
10	40.01.5315	Flat washer 1/2"	08

Note: -Standard Notched Disc: 26"  
-Option Notched Disc: 28" - 40.04.5514





# GICR 18 DISC GANG

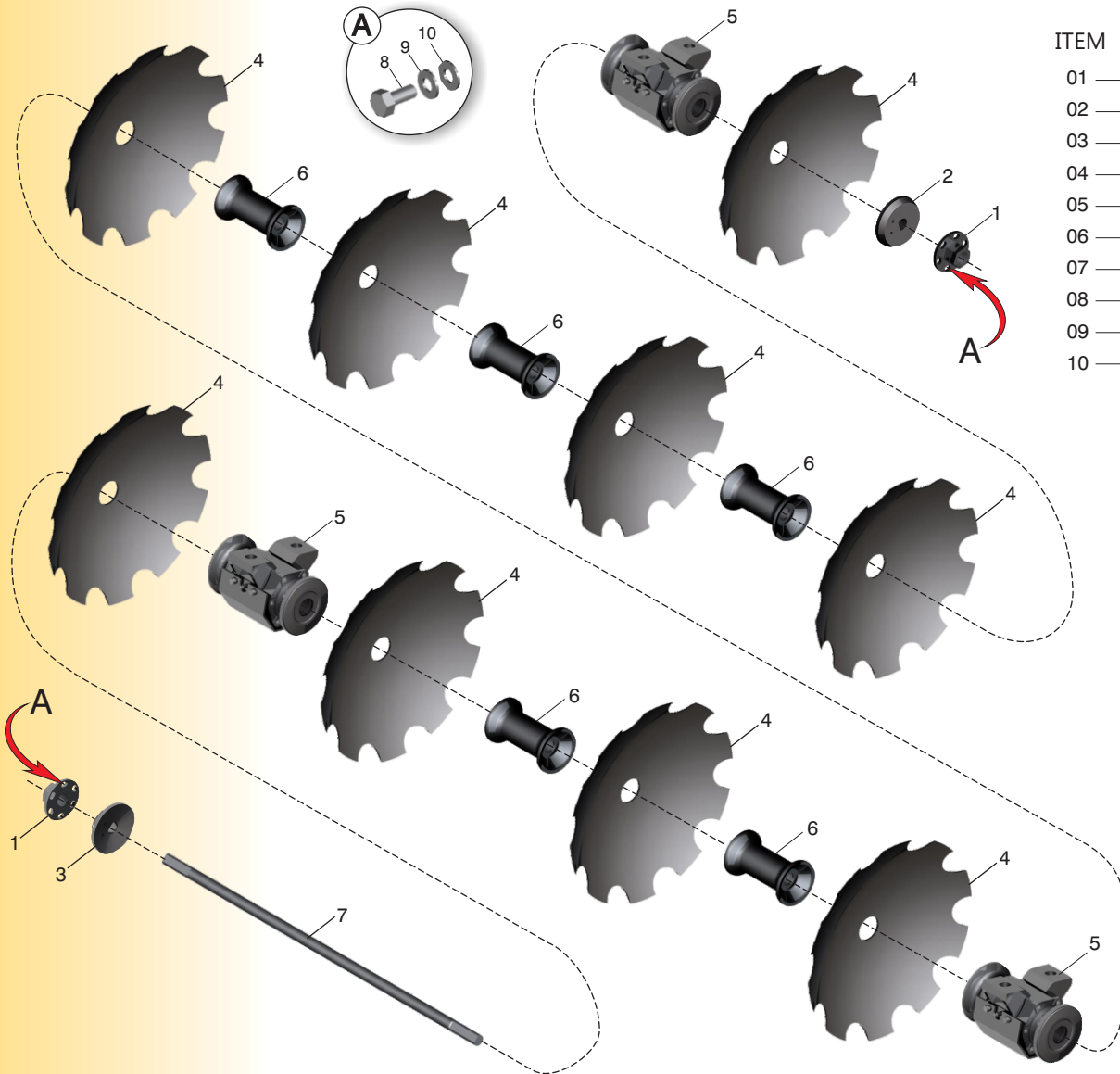

ITEM	CODE	DESCRIPTION	QUANTITY
01	40.16.0324	Flare Nut	04
02	40.01.0324	External Support	02
03	40.01.0323	Internal Support	02
04	40.04.5513	Notched Disc 26"	18
05	40.13.0137	Oil Bath Bearing 263mm (page 06)	06
06	40.19.0044	Spacer 263mm	10
07	40.05.0198	Shaft 1.5/8" x 2360mm	02
08	40.16.0155	Hex. Bolt 1/2" x 1.1/4" UNC	08
09	40.01.5411	Spring washer 1.2"	08
10	40.01.5315	Flat washer 1/2"	08

Note: -Standard Notched Disc: 26"  
-Option Notched Disc: 28" - 40.04.5514





# GICR 20 DISC GANG

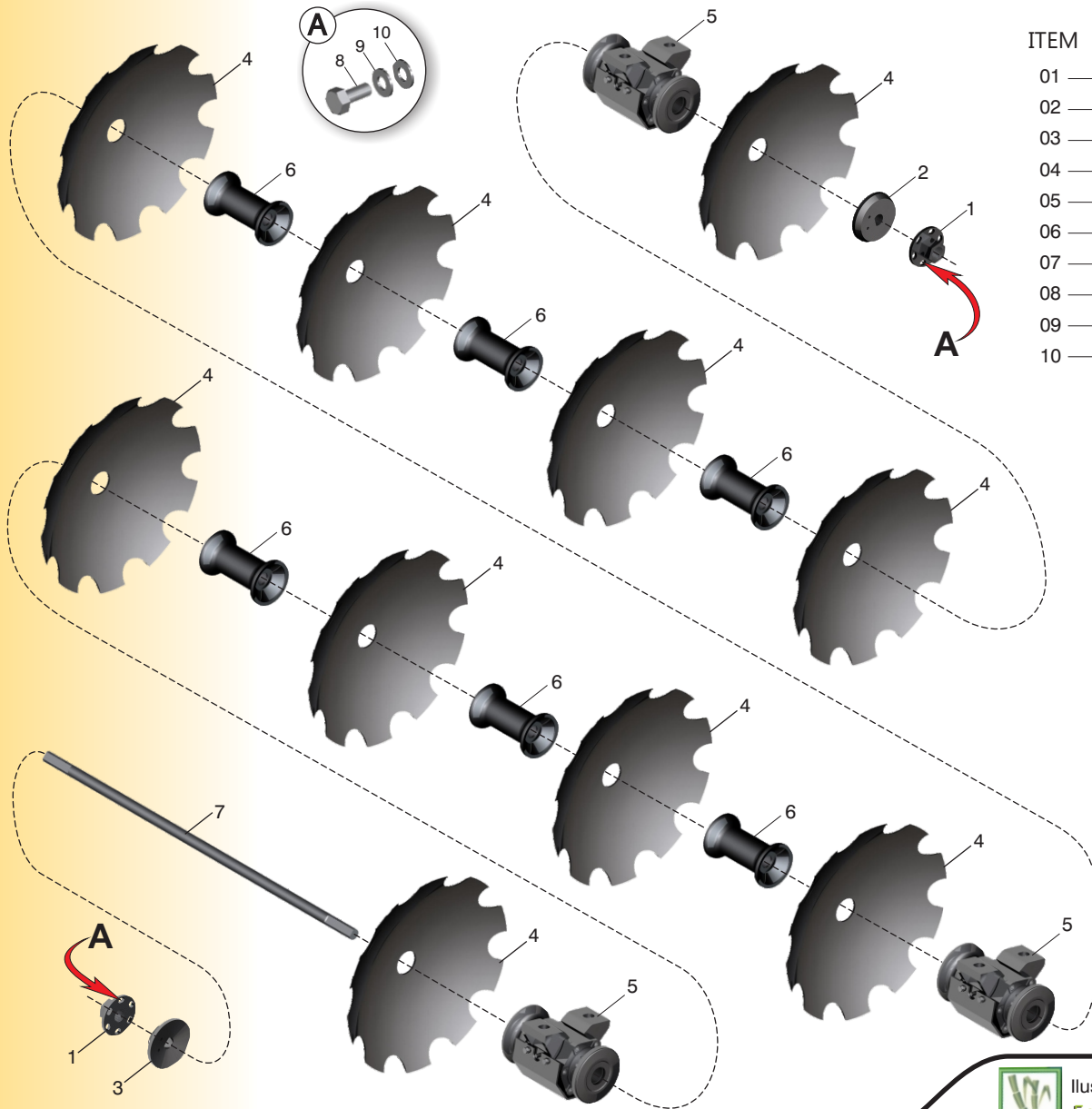

ITEM	CODE	DESCRIPTION	QUANTITY
01	40.16.0324	Flare Nut	04
02	40.01.0324	External Support	02
03	40.01.0323	Internal Support	02
04	40.04.5513	Notched Disc 26"	20
05	40.13.0137	Oil Bath Bearing 263mm (page 06)	06
06	40.19.0044	Spacer 263mm	12
07	40.05.0214	Shaft 1.5/8" x 2630mm	02
08	40.16.0155	Hex. Bolt 1/2" x 1.1/4" UNC	08
09	40.01.5411	Spring washer 1.2"	08
10	40.01.5315	Flat washer 1/2"	08

Note: -Standard Notched Disc: 26"  
-Option Notched Disc: 28" - 40.04.5514





## GICR 24 DISC GANG

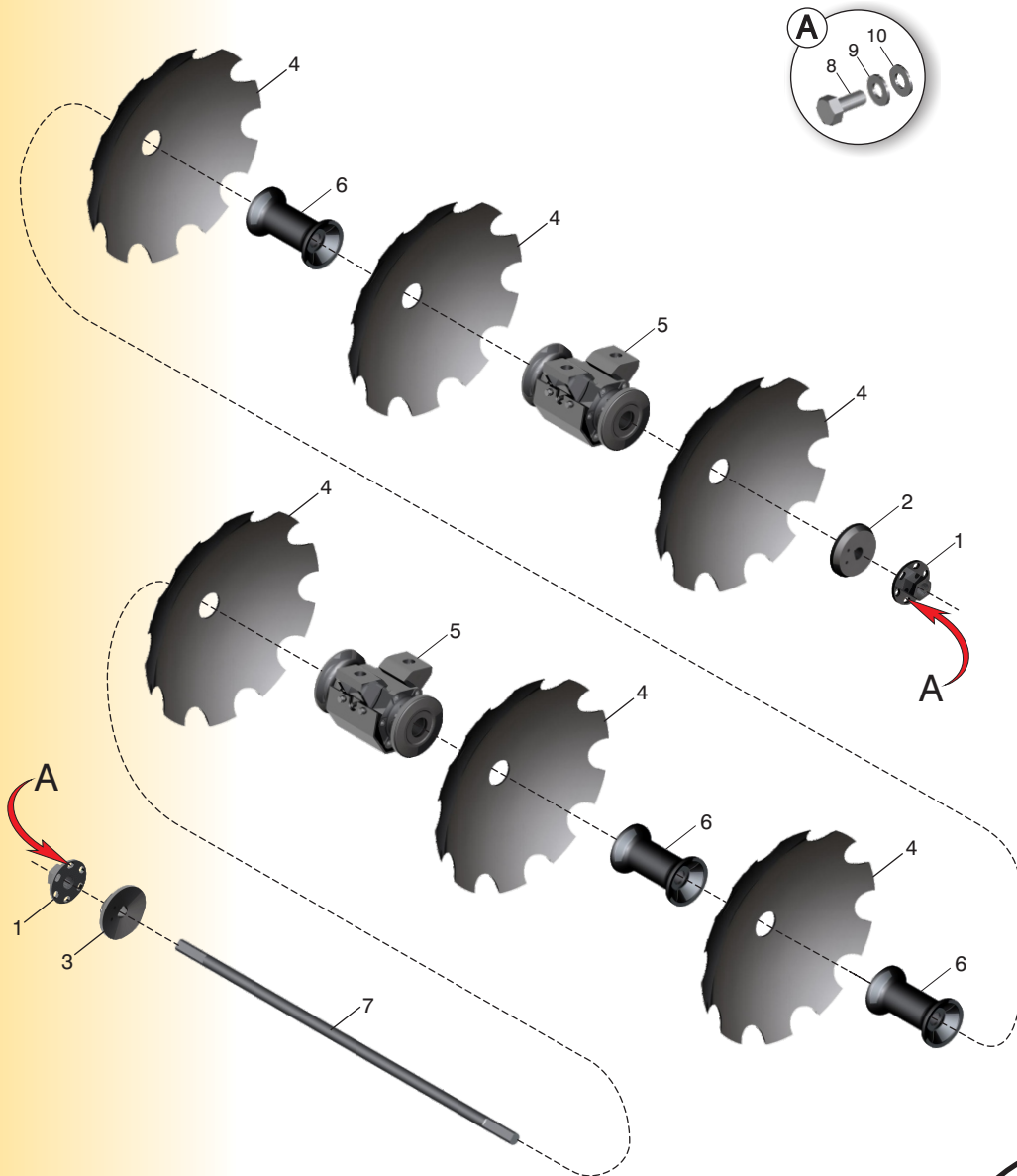

ITEM	CODE	DESCRIPTION	QUANTITY
01	40.16.0324	Flare Nut	08
02	40.01.0324	External Support	04
03	40.01.0323	Internal Support	04
04	40.04.5513	Notched Disc 26"	24
05	40.13.0137	Oil Bath Bearing 263mm (page 06)	08
06	40.19.0044	Spacer 263mm	12
07	40.05.0191	Shaft 1.5/8" x 1565mm	04
08	40.16.0155	Hex. Bolt 1/2" x 1.1/4" UNC	16
09	40.01.5411	Spring washer 1.2"	16
10	40.01.5315	Flat washer 1/2"	16

Note: -Standard Notched Disc: 26"  
-Option Notched Disc: 28" - 40.04.5514





## GICR 28 DISC GANG

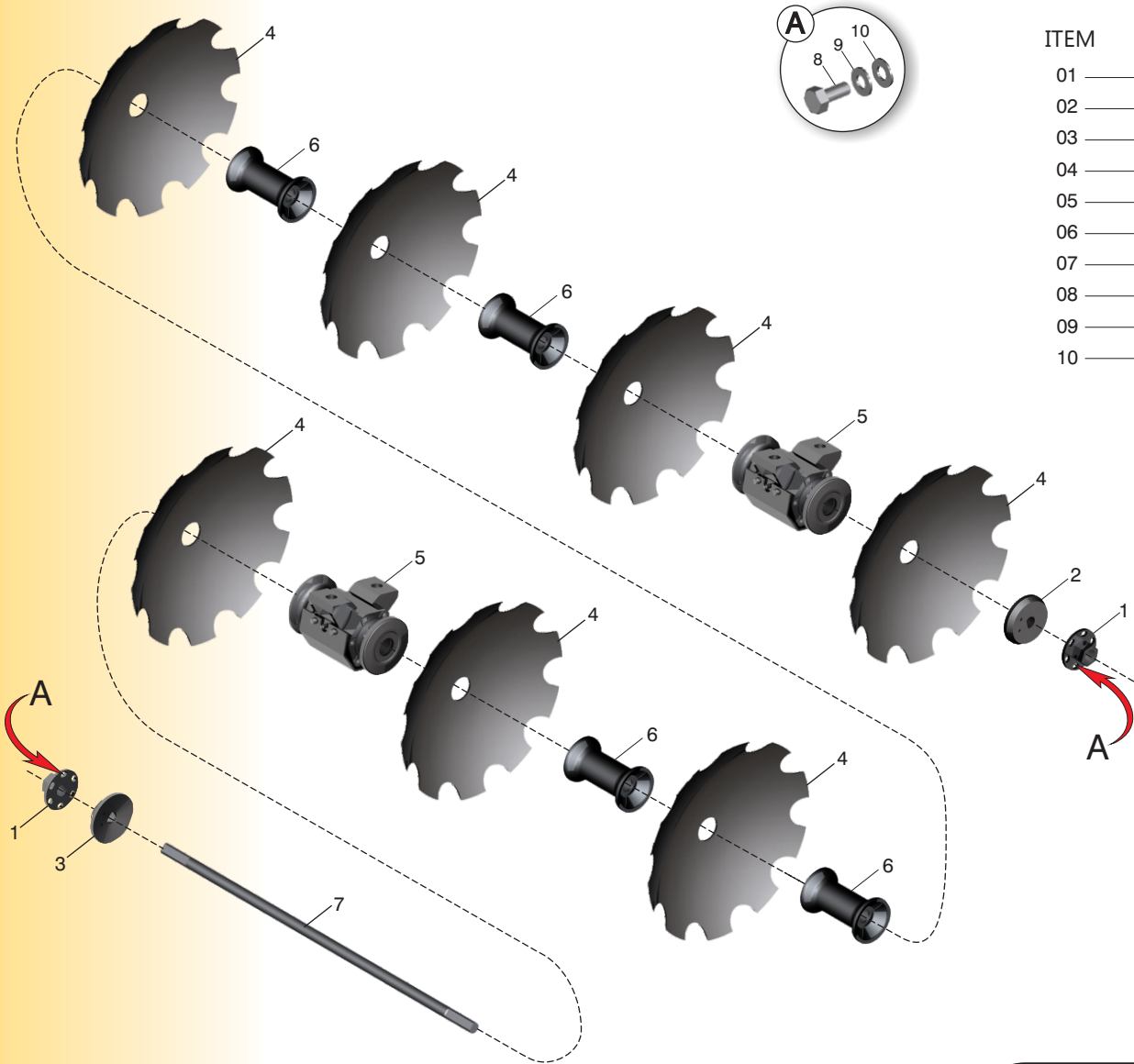

ITEM	CODE	DESCRIPTION	QUANTITY
01	40.16.0324	Flare Nut	08
02	40.01.0324	External Support	04
03	40.01.0323	Internal Support	04
04	40.04.5513	Notched Disc 26"	28
05	40.13.0137	Oil Bath Bearing 263mm (page 06)	08
06	40.19.0044	Spacer 263mm	16
07	40.05.0192	Shaft 1.5/8" x 1825mm	04
08	40.16.0155	Hex. Bolt 1/2" x 1.1/4" UNC	16
09	40.01.5411	Spring washer 1.2"	16
10	40.01.5315	Flat washer 1/2"	16

Note: -Standard Notched Disc: 26"  
-Option Notched Disc: 28" - 40.04.5514





## WHEEL SET

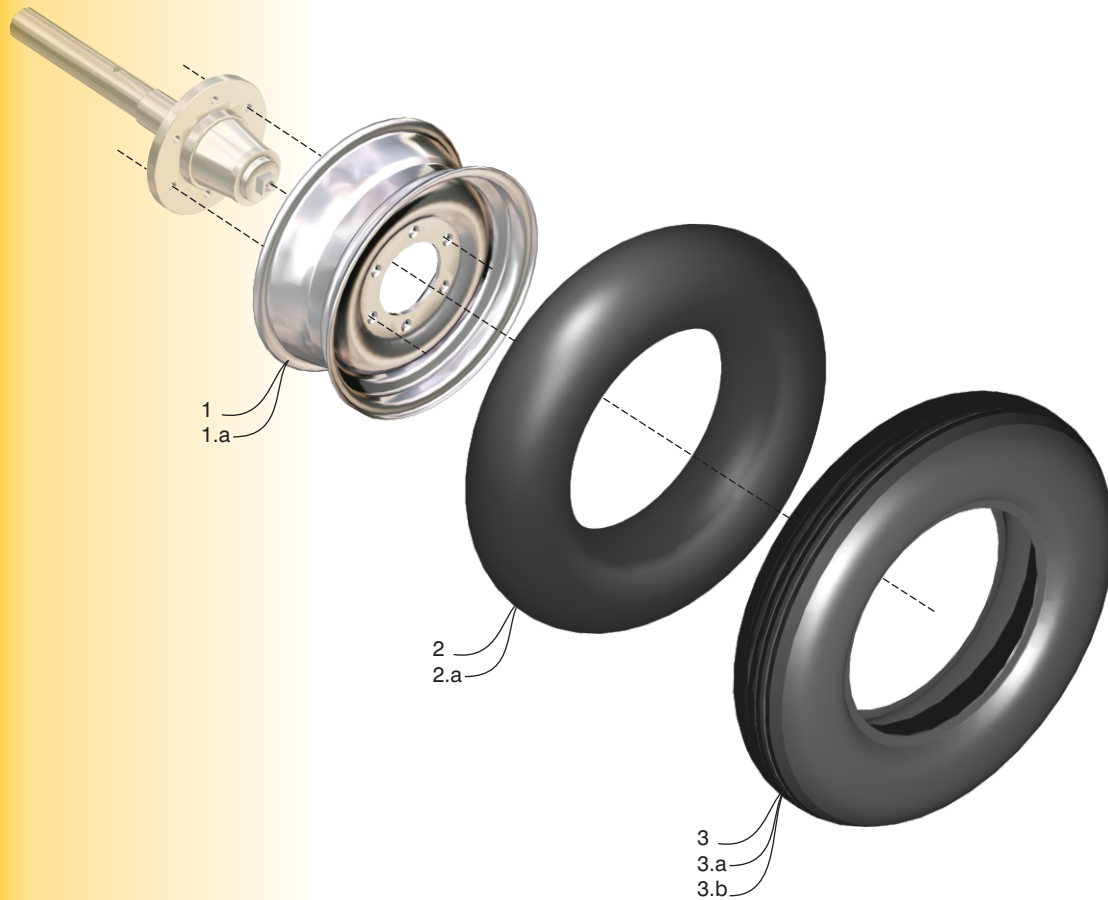

### Assembled Wheel - 6.00 x 16 - Code 20.53.0093

ITEM	CODE	DESCRIPTION	QUANTITY
01	40.18.0071	Wheel	01
02	40.03.0006	Tube	01
03	40.16.0055	Tire 6.00 x 16	01

### Assembled Wheel - 7.50 x 16 - Code 20.53.0097

ITEM	CODE	DESCRIPTION	QUANTITY
01	40.18.0071	Wheel	01
02	40.03.0006	Tube	01
03.a	40.16.0130	Tire 7.50 x 16	01

### Assembled Wheel - 11L-15 - Code 20.18.0113 (Option)

ITEM	CODE	DESCRIPTION	QUANTITY
01.a	40.18.5525	Wheel	01
02.a	40.03.0056	Tube	01
03.b	40.16.5628	Tire 11L-15	01







## Wheel Hub

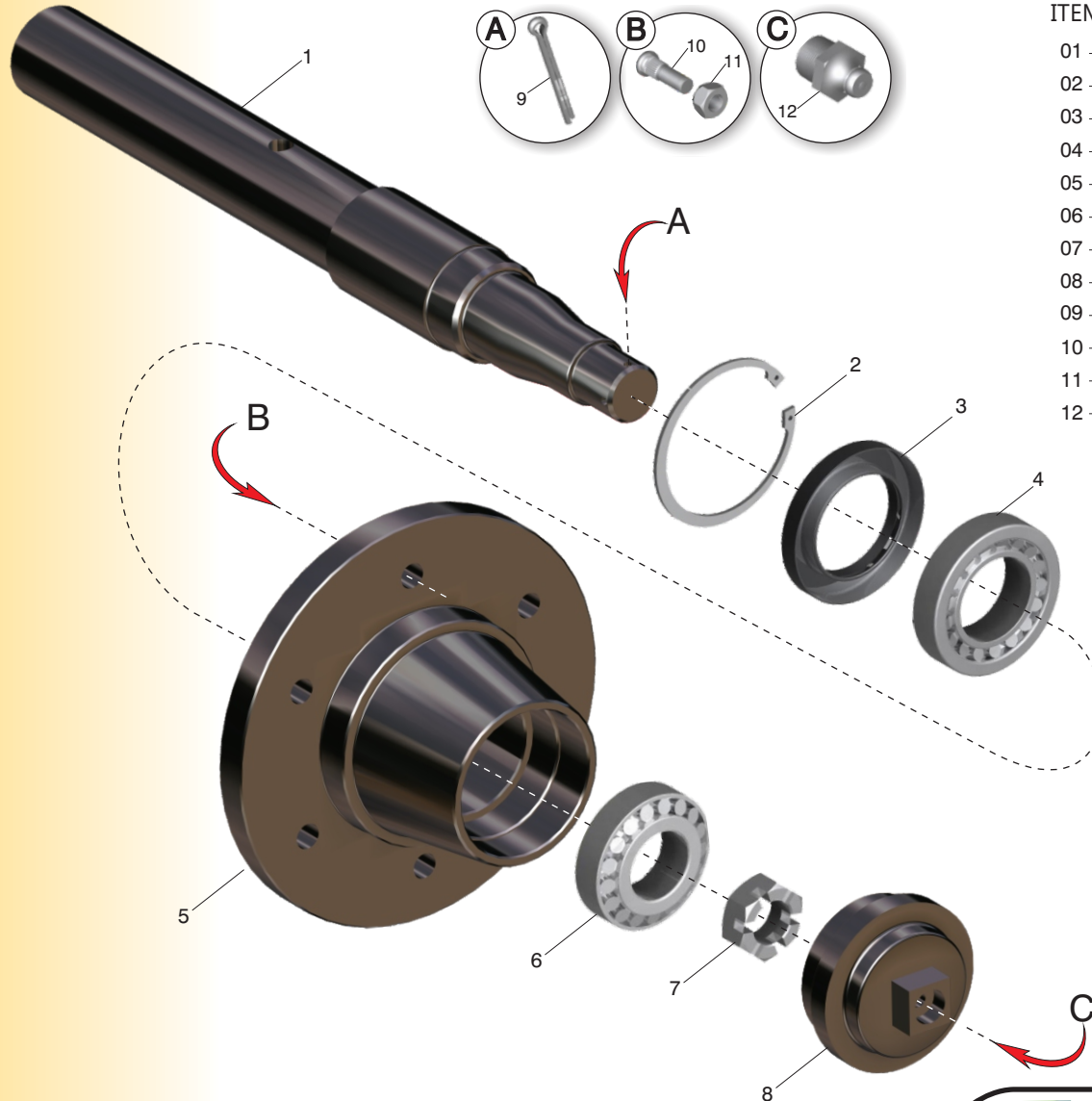

ITEM	CODE	DESCRIPTION	QUANTITY
01	22.33.0058	Wheel Shaft	01
02	40.01.0070	Elastic ring 502095	01
03	40.18.0007	Retainer 5983 ARCA	01
04	40.18.5099	Bearing 32210	01
05	20.32.0072	Hub	01
06	40.18.5098	Bearing 32208	01
07	40.16.5025	Castle Nut 1.3/8" UNF	01
08	20.34.2025	Housing Lid	01
09	40.03.5027	Cotter Pin 3/16"x 2"	01
10	40.16.0020	Bolt 9/16" x 2"	06
11	40.16.7022	Conic Castle Nut 9/16"	06
12	40.07.5034	Grease Nipple 1/8" BSP	01





**SANTA IZABEL**  
*Implementos Agrícolas*

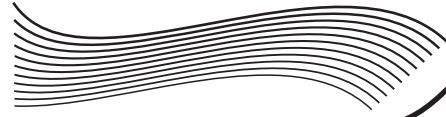

## NOTES

### *Intermediate Disc Harrow Remote Control*

## GICR- 24

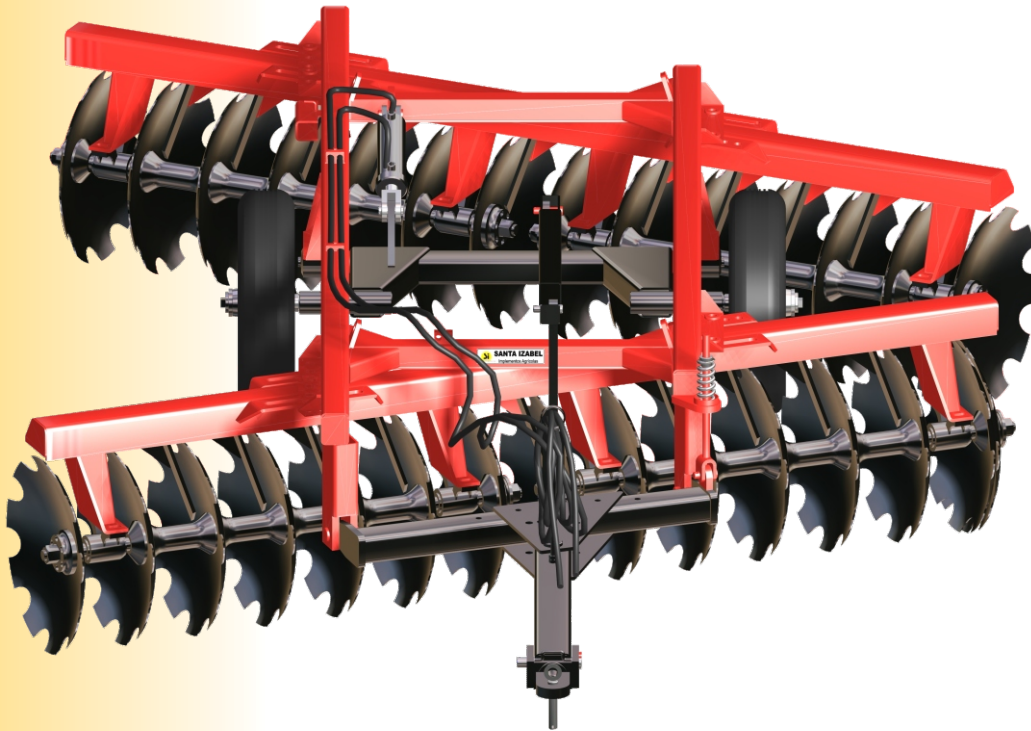

### **SANTA IZABEL Implementos Agrícolas Ltda**

Avenida Dolores Martins Rubinho, 901 - Distrito Industrial II  
CEP: 13.877-757 - São João da Boa Vista - São Paulo - Brasil  
Fone: (+55) (19) 3636.2100 - Fax: (+55) (19) 3636.2105  
e-mail: [santaizabel@santaizabel.ind.br](mailto:santaizabel@santaizabel.ind.br) - Site: [www.santaizabel.ind.br](http://www.santaizabel.ind.br)



Ilustração: \_\_\_\_\_  
Equipcanna - Equipamentos Agrícolas

**Parts Catalogue  
2012**

